

PIPER AIRCRAFT CORPORATION

LOCK HAVEN, PENNA.

PAGE 1, Sec. 2

PA-23-250 (Six-Place)

S/N 27-2505 & Up

PIPER AIRCRAFT CORPORATION
LOCK HAVEN, PENNSYLVANIA

GYPSUM HAULAGE, INC.
P. O. BOX
BURLINGTON, N. J.

ACTUAL WEIGHT AND BALANCE, AND LOADING SCHEDULE

MODEL PA-23-250 (SIX-PLACE)

S/N 27-2505 AND UP

SERIAL NUMBER 27- 3541

DUPLICATE 8/5/68

IDENTIFICATION NO. N6291Y

DATE: 3-21-67

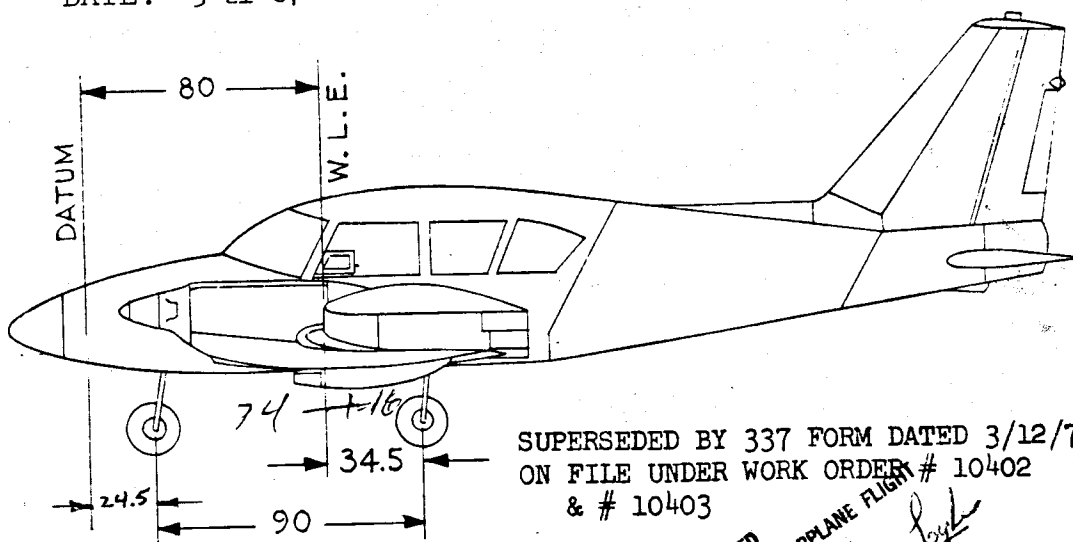

SUPERSEDED BY 337 FORM DATED 3/12/70
ON FILE UNDER WORK ORDER # 10402
& # 10403

NEW EMPTY WEIGHT

3266.6

ARM

SEE WGT. & BALANCE SECTION AIRPLANE FLIGHT
MANUAL FOR CURRENT DATA.
Date: 1-6-78
PIPER AIRCRAFT, INC. APP. 4125A

MOMENT

294758.7

Empty Weight as Weighed
(Includes Items Checked on Equipment List)

Left Wheel	1191
Right Wheel	1185
Nose Wheel (N)	873
Total (T)	3249

~~Superseded by 337 Form~~
~~Deleted by Log~~
~~Book Entry~~
11-14-69

PIPER AIRCRAFT CORPORATION

LOCK HAVEN, PENNA.

REPORT 1360 .

PAGE 10, Sec. 2
PA-23-250 (Six-Place

MODEL
S/N 27-2205 & 30

NOTE:

I When seats are removed for cargo stowage, the Basic Weight and corresponding C.G. must be corrected prior to determination of the loading schedule. The weights and arms for these seats are:

Item	Weight	Arm	Moments
Co-Pilot's Seat and Headrest	23	89	2047
Middle Seat & Headrest (each)	24	126	3024
Rear Seat (Total)	26 1/2	157	4161

II The normal disposable load items and arms are:

Item	Weight	Arm	Moment
Front Occupants	Use Actual	89	-
Middle Occupants	Use Actual	126	-
Rear Occupants	Use Actual	157	-
Forward Baggage	(150 Max.)	10	-
Rear Baggage	(150 Max.)	183	-
Fuel (36 gal. each tank)	216	113	24408
Fuel (140 gal. total)*	840*	113	94920

*4 gal. of unusable fuel is already included in Empty and Basic Weight and C.G. determinations. Total fuel capacity 144 gal.

